

REV	NOTES	DATE	APPROVED
A	INITIAL RELEASE		

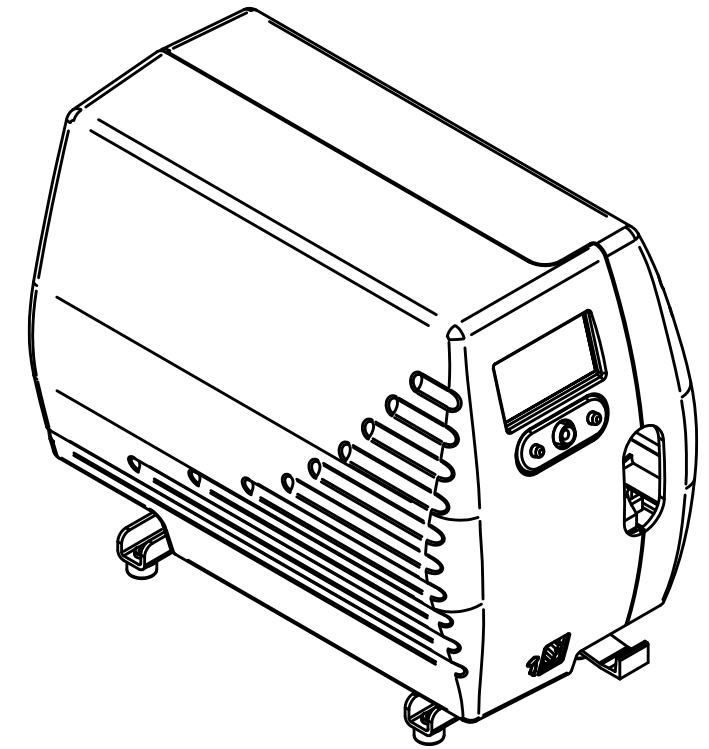

DESCRIPTION: Pslim, Specimen Slide Laboratory Identification Machine		PART No: 61311	REV.: L
USED ON:	QTY.	MATERIAL:	FINISH:
SHEET 1 OF 1			
0.01 BREAK ON ALL SHARP EDGES UNLESS OTHERWISE SPECIFIED	DRAWN BY: TH DATE: 1/15/2008 DESIGNED BY: JS DATE: 10/16/2007 APPROVED BY:	TOLERANCES UNLESS OTHERWISE SPECIFIED: X.XX ± 0.010 X.XXX ± 0.005 X.XXXX ± 0.0005 HOLE DIA. + 0.005 ANGULAR ± 0.3°	THIRD ANGLE PROJECTION UNITS: IN [mm]
DO NOT SCALE DRAWING	<small>CONFIDENTIAL - PROPRIETARY</small> <small>THE INFORMATION IN THIS DOCUMENT IS PROPRIETARY TO AUTOMATIC MANUFACTURING SYSTEMS, INC. AND SHALL NOT BE USED OR DISCUSSED IN WHOLE OR IN PART WITHOUT THE WRITTEN CONSENT OF AUTOMATIC MANUFACTURING SYSTEMS, INC.</small>		

REV	NOTES	DATE	APPROVED
A	INITIAL RELEASE		

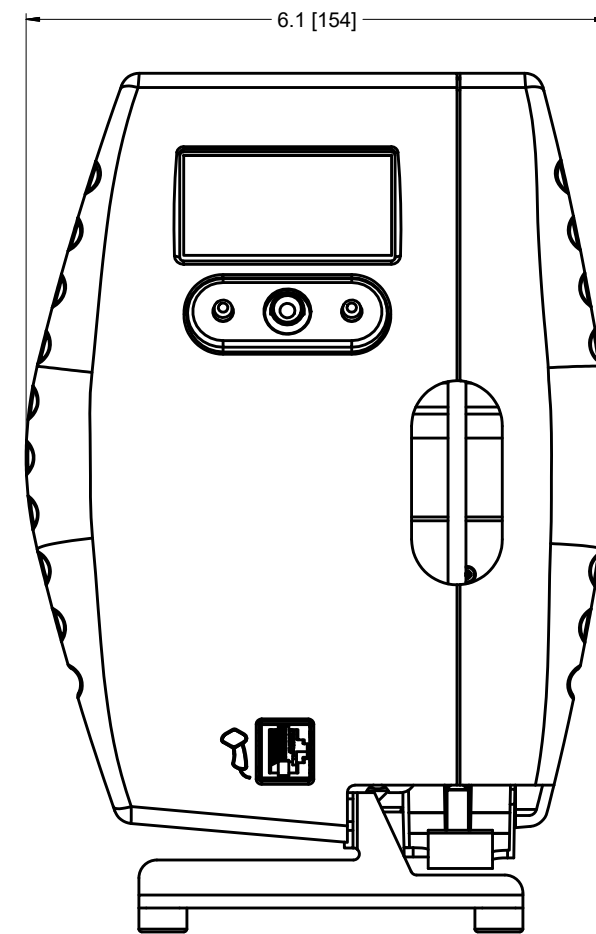
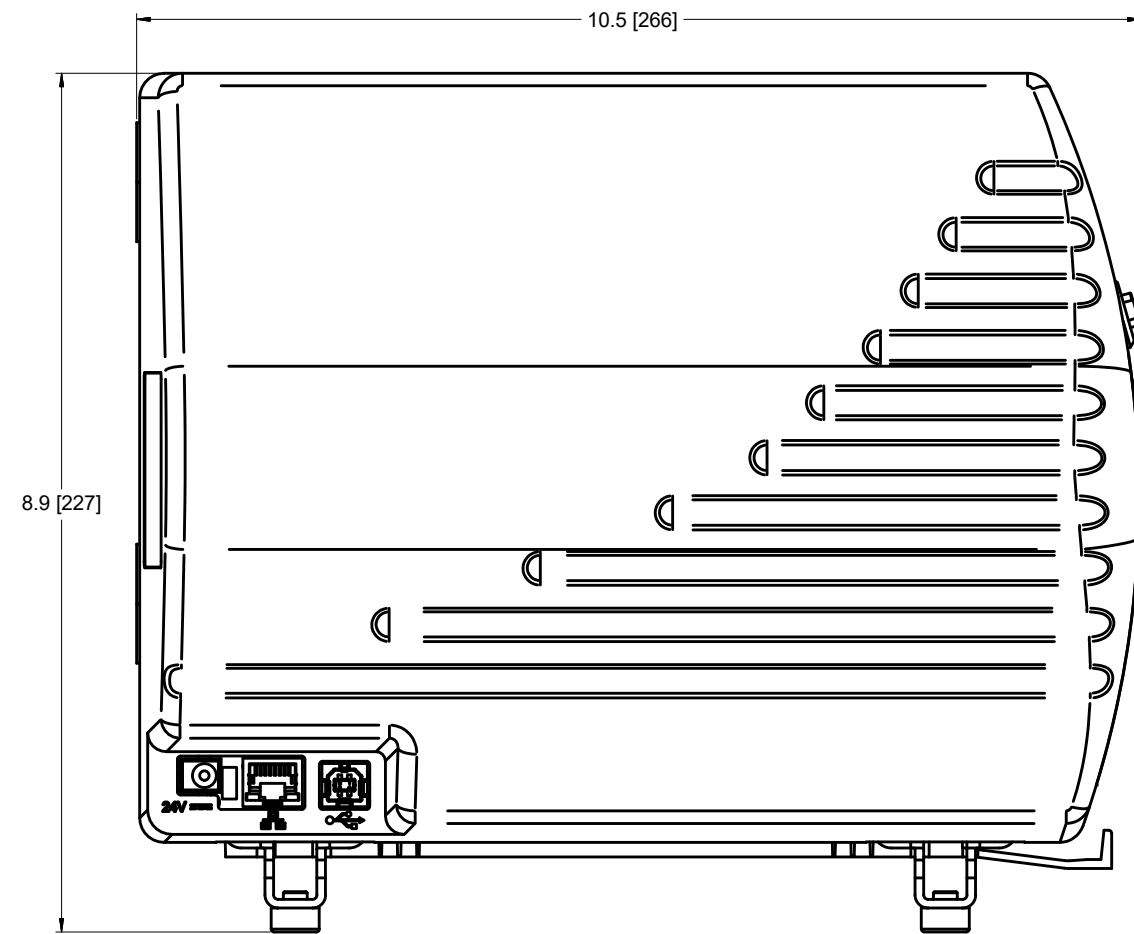

		DESCRIPTION: Pslim, Specimen Slide Laboratory Identification Machine		PART No: 61311	REV.: L
USED ON:		MATERIAL:		FINISH:	
SHEET OF 1		DRAWN BY: TH		TOLERANCES UNLESS OTHERWISE SPECIFIED	
0.01 BREAK ON ALL SHARP EDGES UNLESS OTHERWISE SPECIFIED		DATE 1/15/2008		± 0.010 ± 0.005 ± 0.0005	
		DESIGNED BY: JS		DATE 10/16/2007	
DO NOT SCALE DRAWING		APPROVED BY:		DATE	
		HOLE DIA.:		± 0.005	
		ANGULAR		± 0.3°	
				UNITS: IN [mm]	
<small>CONFIDENTIAL - PROPRIETARY THE INFORMATION IN THIS DOCUMENT IS PROPRIETARY TO AUTOMATIC MANUFACTURING SYSTEMS, INC. AND SHALL NOT BE USED OR DISCUSSED IN WHOLE OR IN PART WITHOUT THE WRITTEN CONSENT OF AUTOMATIC MANUFACTURING SYSTEMS, INC.</small>					