

REV	NOTES	DATE	APPROVED
A	INITIAL RELEASE	Jan. 20, 2016	AS

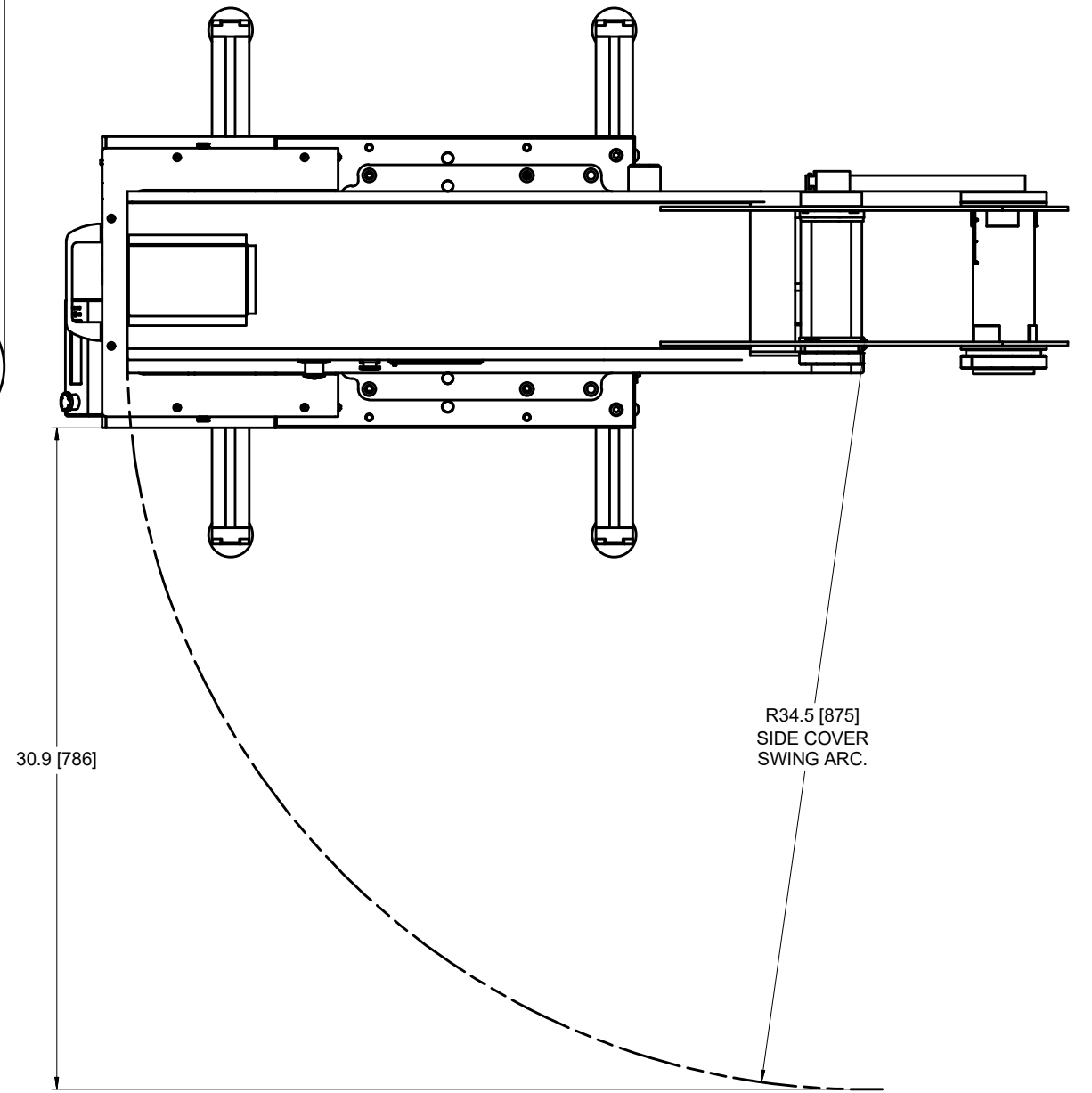
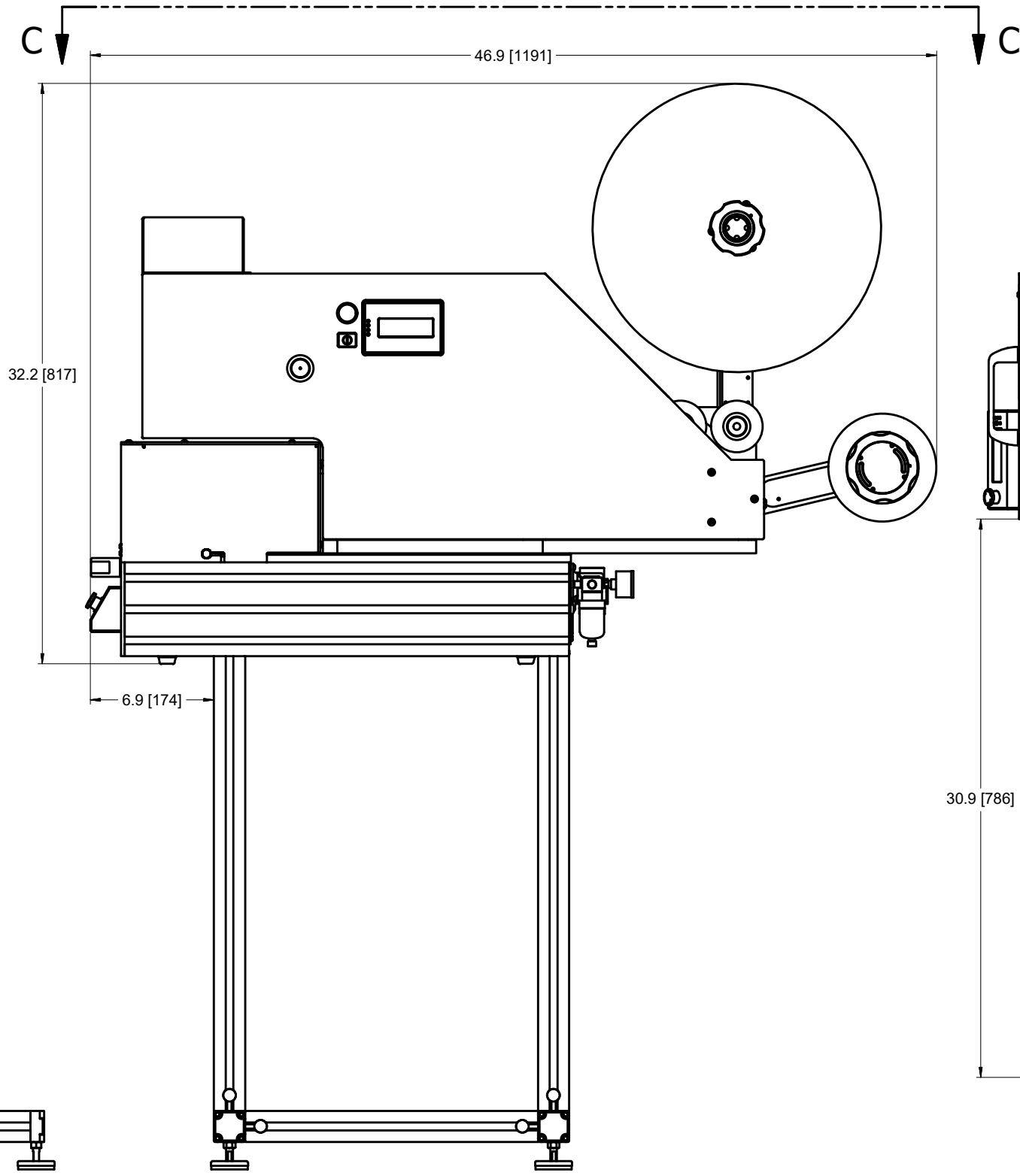
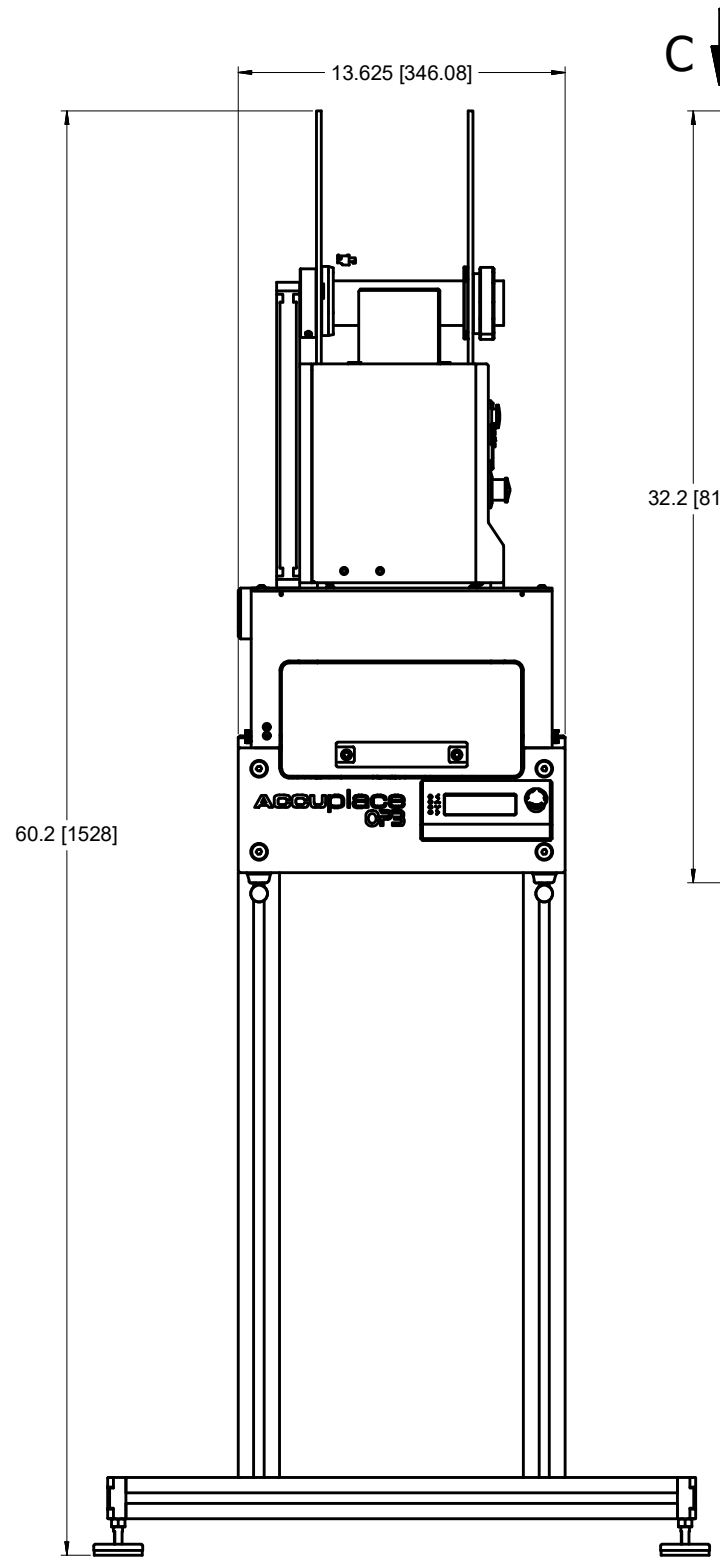

VIEW C-C

OP3 with Stand and AP4065

DESCRIPTION: Document, Configuration Layout, OP3		PART No: 66313	REV.: A
USED ON: SHEET 7 OF 9	MATERIAL:	FINISH:	
0.01 BREAK ON ALL SHARP EDGES UNLESS OTHERWISE SPECIFIED	DRAWN BY: Tony Haubrich DATE: 9/1/2015 DESIGNED BY: Tony Haubrich DATE: 7/17/2015	TOLERANCES UNLESS OTHERWISE SPECIFIED X.XX ± 0.010 X.XXX ± 0.005 X.XXXX ± 0.0005	
DO NOT SCALE DRAWING	APPROVED BY: H. Shahrestani DATE: 1/20/2016	HOLE DIA. + 0.005 ANGULAR ± 0.3°	THIRD ANGLE PROJECTION
UNITS: IN [mm]			

CONFIDENTIAL - PROPRIETARY
 THE INFORMATION IN THIS DOCUMENT IS PROPRIETARY TO AUTOMATIC MANUFACTURING SYSTEMS, INC. AND SHALL NOT BE USED OR DISCLOSED IN WHOLE OR IN PART WITHOUT THE WRITTEN CONSENT OF AUTOMATIC MANUFACTURING SYSTEMS, INC.