

REV.	NOTES	DATE	APPROVAL
A	INITIAL RELEASE		

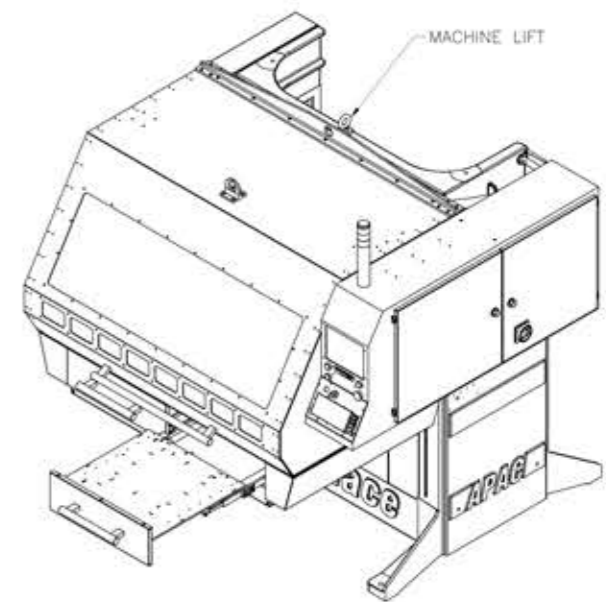

DETAIL A

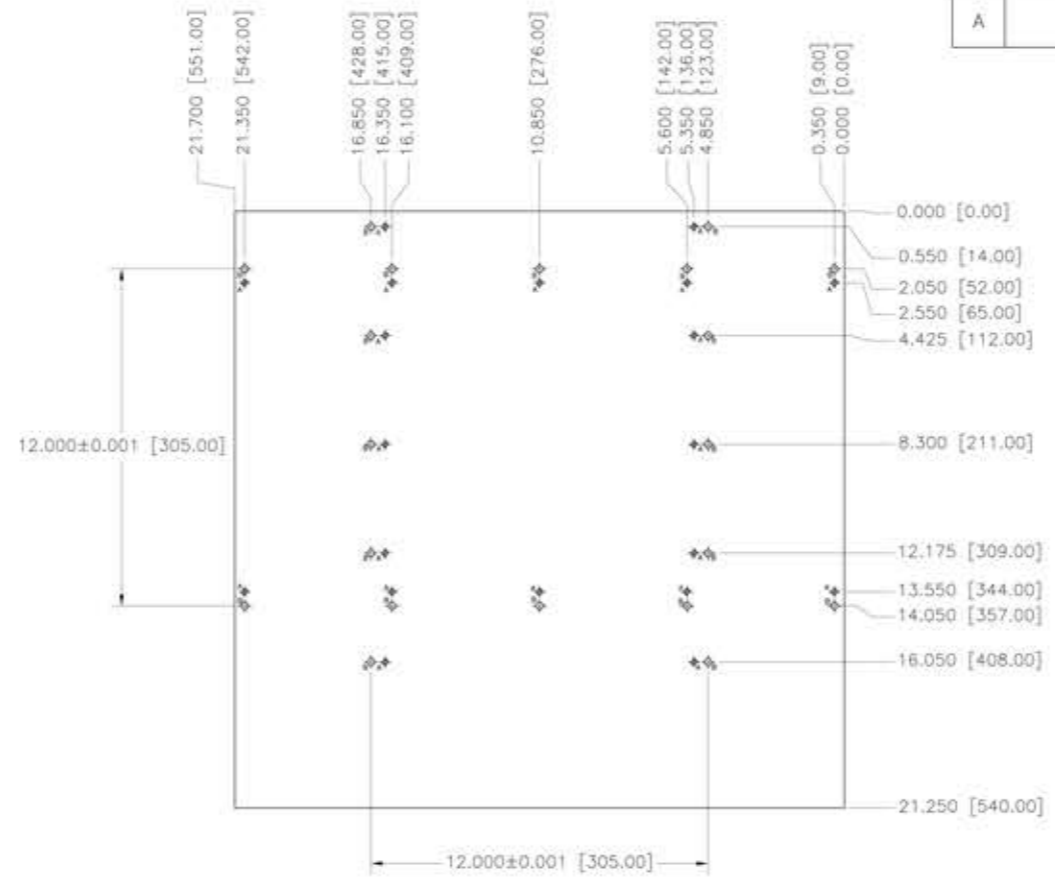
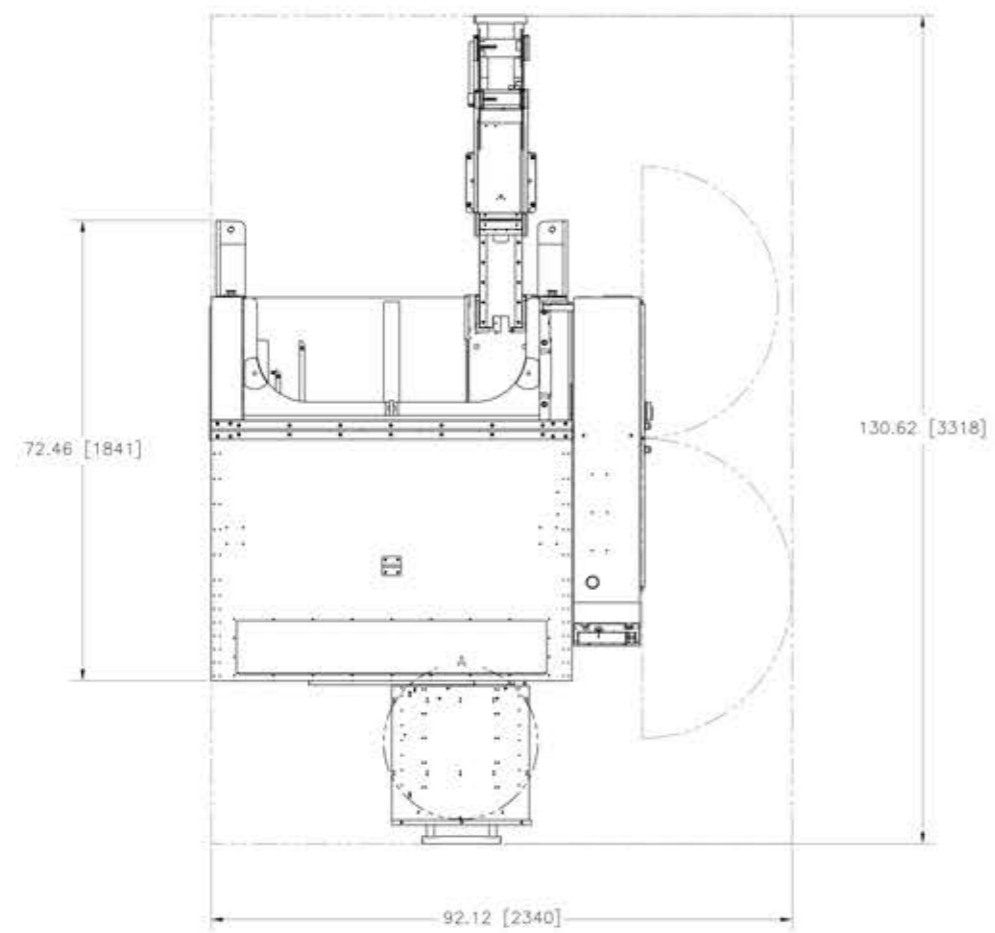
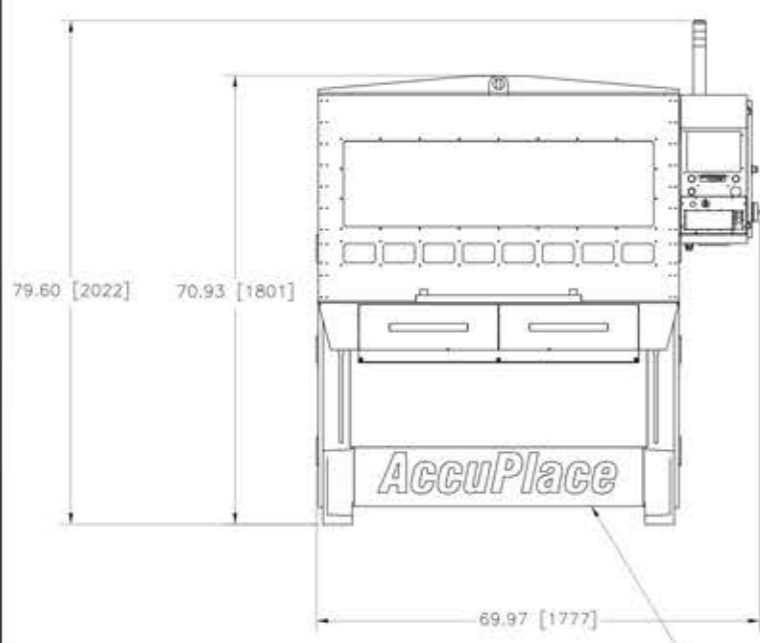

FORKLIFT/PALLET JACK ACCESS

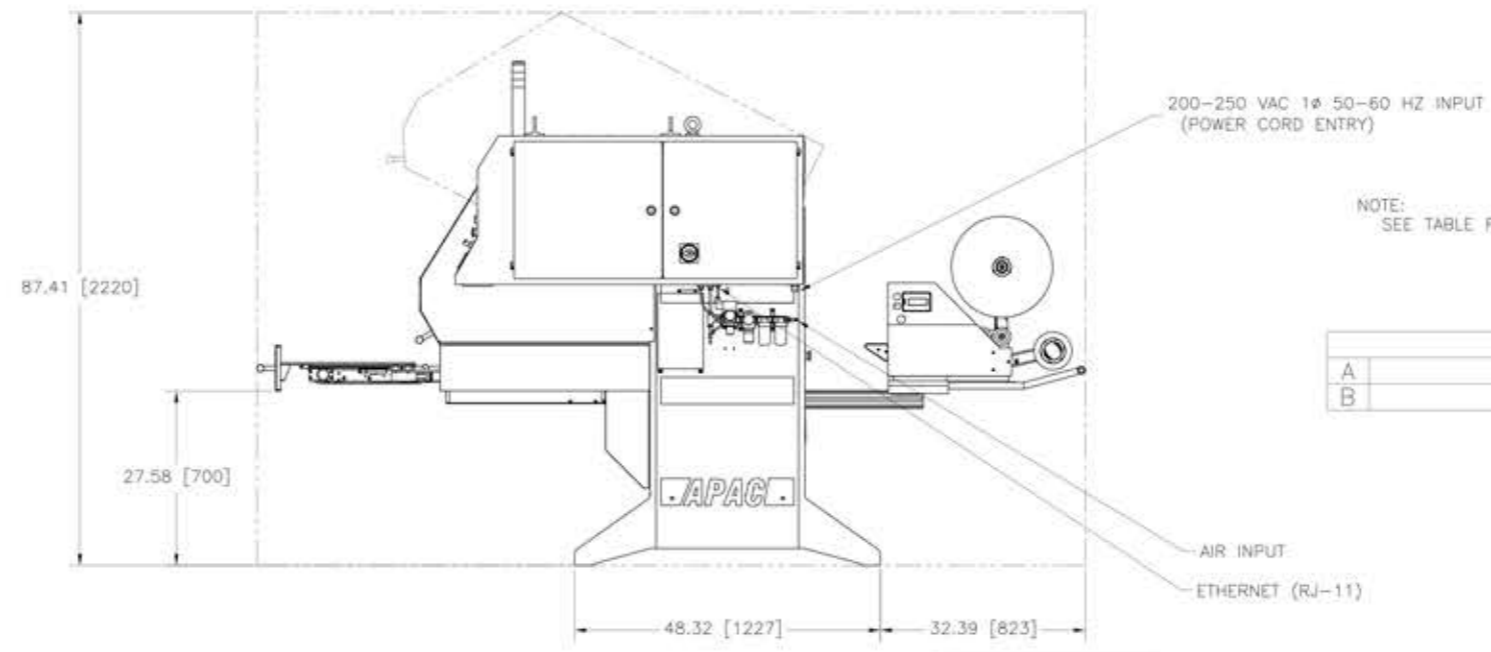

NOTE:
SEE TABLE FOR TOOLING HOLE DETAILS IN DETAIL A

HOLE INDEX	
A	M4 x 0.7 THRU
B	Ø.2518 x 0.27 DP.

USED ON: QTY.		DESCRIPTION:		PART NO.:	
SHEET 1 OF 1		APAC with Dual Tray Shuttle Option			
MATERIAL: N/A		FINISH: N/A		THIRD ANGLE PROJECTION	
0.02 BREAK ON ALL SHARP EDGES UNLESS OTHERWISE SPECIFIED		DRAWN BY: Freddy Molina DATE: 04/24/03		TOLERANCES UNLESS OTHERWISE SPECIFIED	
		DESIGNED BY: Freddy Molina DATE: 04/24/03		X.XX ±0.010	
		APPROVED BY: DATE:		X.XXX ±0.005	
DO NOT SCALE DRAWING				X.XXXX ±0.0005	
				HOLE DIA. + 0.005	
				ANGULAR ± 0.3°	
				UNITS: INCHES	
<small>CONFIDENTIAL-PROPRIETARY THE INFORMATION IN THIS DOCUMENT IS PROPRIETARY TO AUTOMATIC MANUFACTURING SYSTEMS INC. AND SHALL NOT BE USED OR DISCUSSED IN WHOLE OR IN PART WITHOUT THE WRITTEN CONSENT OF AUTOMATIC MANUFACTURING SYSTEMS INC.</small>					