

REV	NOTES	DATE	APPROVED
A	INITIAL RELEASE	Jan. 20, 2016	AS

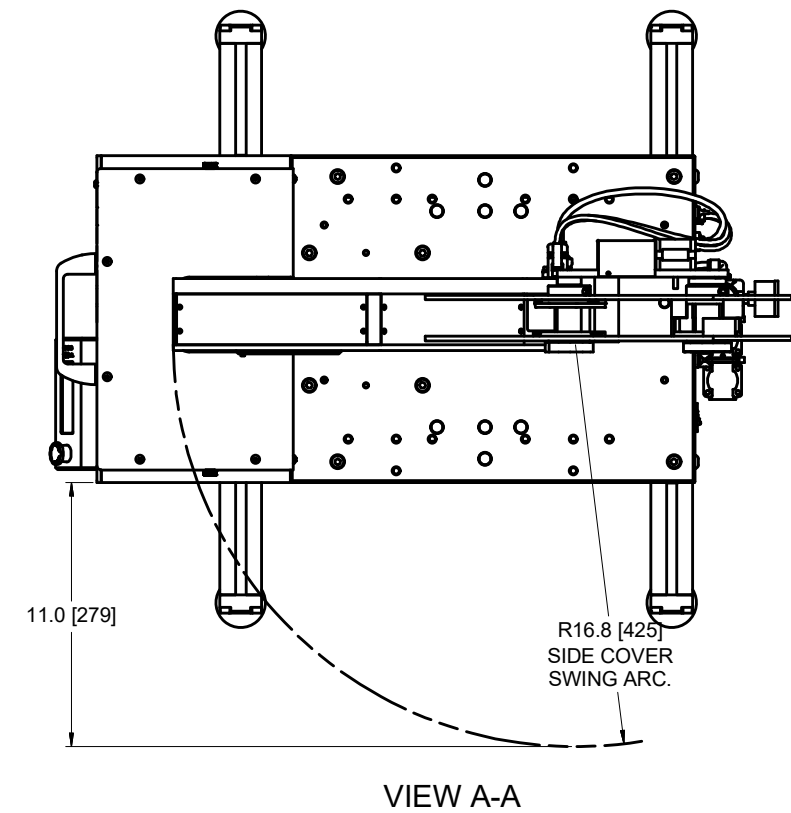
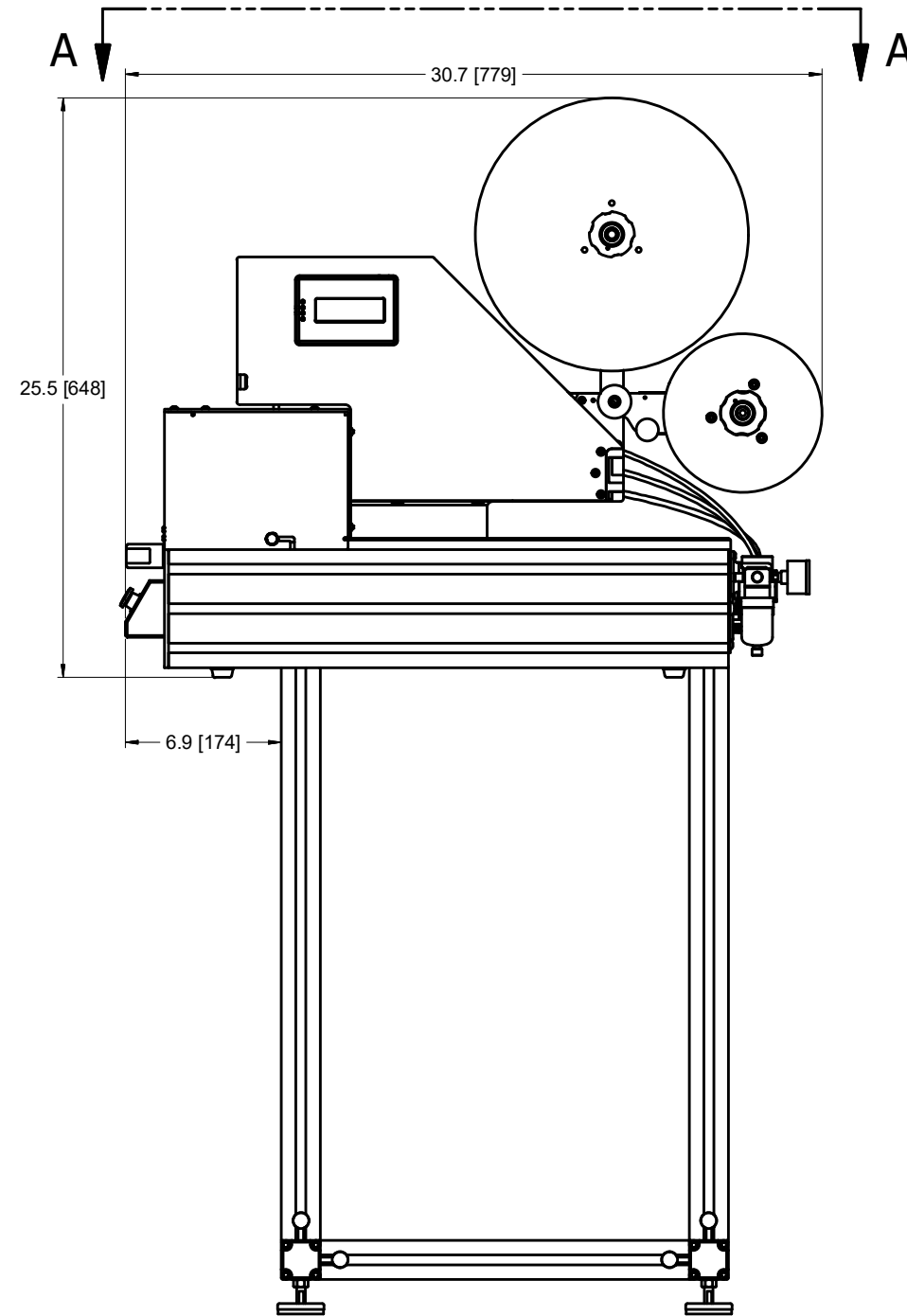
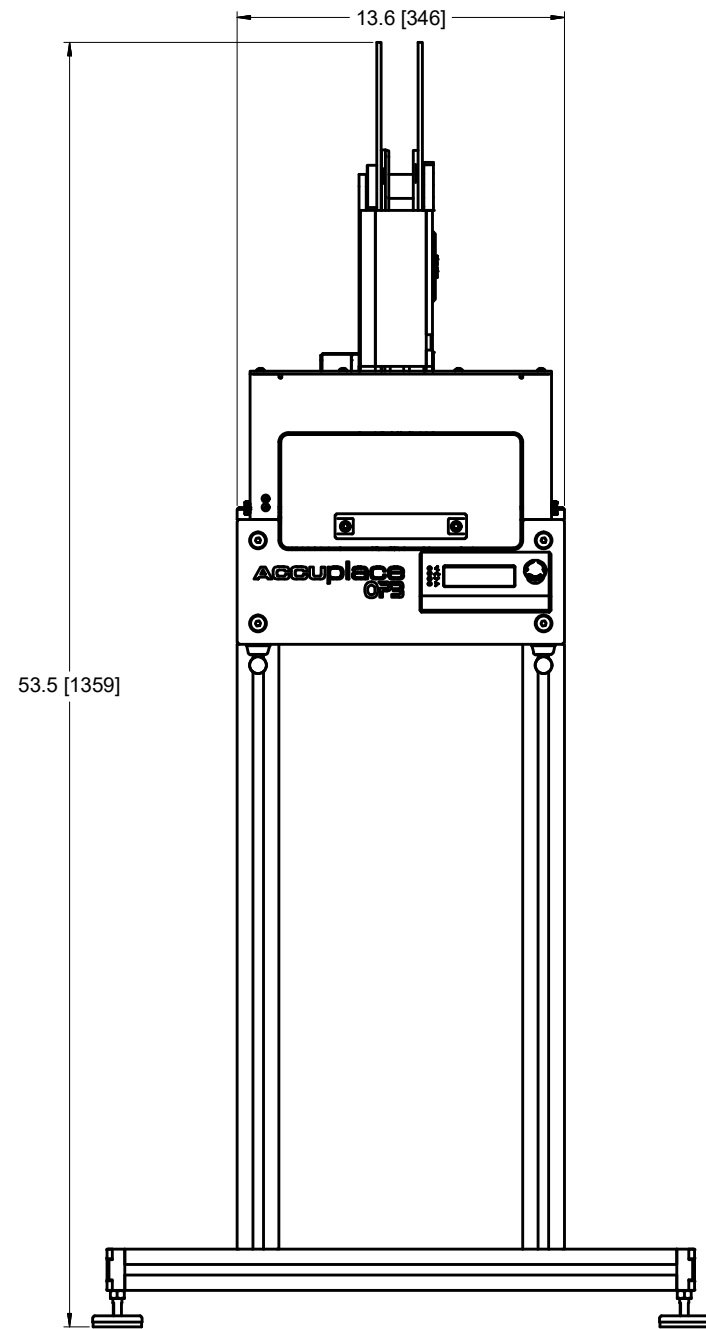

OP3 with Stand and AP1515

DESCRIPTION: Document, Configuration Layout, OP3		PART No: 66313	REV.: A
USED ON: SHEET 5 OF 9	QTY.	MATERIAL:	FINISH:
0.01 BREAK ON ALL SHARP EDGES UNLESS OTHERWISE SPECIFIED	DRAWN BY: Tony Haubrich	DATE 9/1/2015	TOLERANCES UNLESS OTHERWISE SPECIFIED X.XX ± 0.010 X.XXX ± 0.005 X.XXXX ± 0.0005
DO NOT SCALE DRAWING	DESIGNED BY: Tony Haubrich	DATE 7/17/2015	HOLE DIA. + 0.005 ANGULAR ± 0.3°
APPROVED BY: H. Shahrestani		DATE 1/20/2016	THIRD ANGLE PROJECTION

ACCUpLACE

CONFIDENTIAL - PROPRIETARY
THE INFORMATION IN THIS DOCUMENT IS PROPRIETARY TO AUTOMATIC MANUFACTURING SYSTEMS, INC. AND SHALL NOT BE USED OR DISCLOSED IN WHOLE OR IN PART WITHOUT THE WRITTEN CONSENT OF AUTOMATIC MANUFACTURING SYSTEMS, INC.

UNITS: IN [mm]